

Chapter 6

Project Time Planning and Networks

Project Management for Business,
Engineering, and Technology

Prepared by

Herman Steyn, Ph.D.

University of Pretoria

&

John Nicholas, Ph.D.

Loyola University Chicago

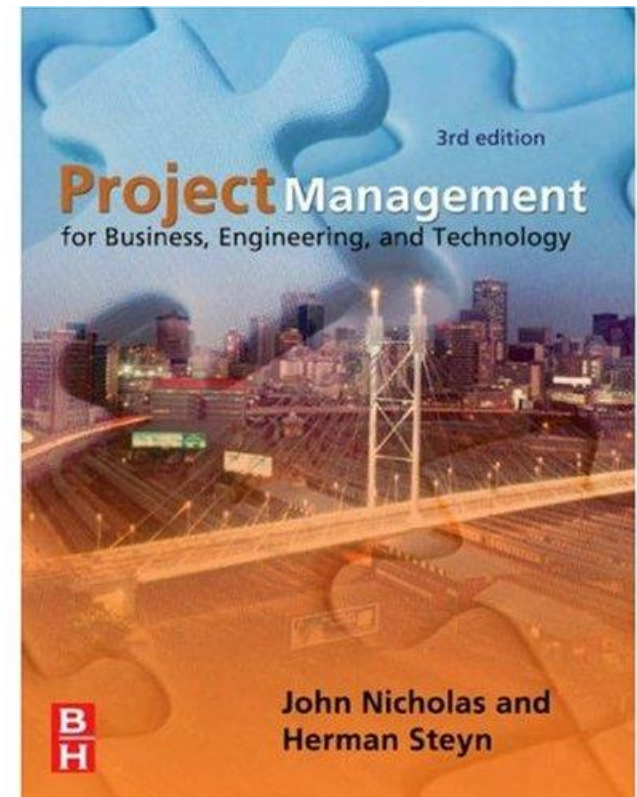

Scheduling Using Network Methods

- Network methods are more sophisticated planning tools than are Gantt charts
 - A Gantt chart should be drawn *after* a network has been developed (as will be discussed later)
 - Two network methods: Activity on Node (AON) and Activity on Arrow (AOA)
-

Activity-On Node (AON)

- AON: “Activity on Node”
- Each schedule activity in project is represented by a node or block



- A project is represented by a network of nodes connected with arrows arranged in sequence as specified by immediate predecessors
-

AON (cont'd)

■ Example

Activity	Immediate Predecessors
A	--
B	A
C	B
D	B
E	C, D
F	E

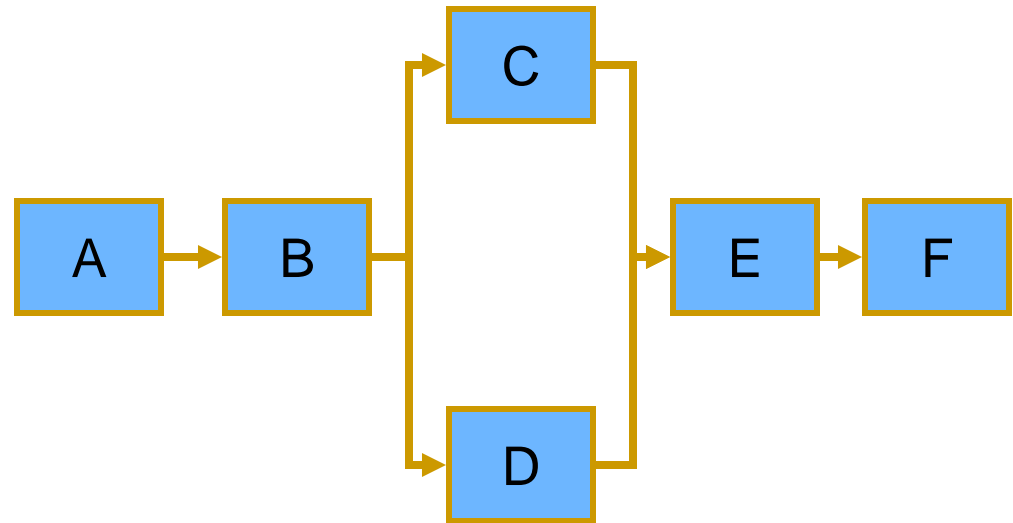

Given a table like the one above, developing the network is a mechanistic process that does not require any decisions

Activity-On Node (AON)

In Chapter 5 we indicated that Gantt charts can be drawn for work at different levels within the WBS

Schedule activities in a network can also represent work at different levels

A schedule activity at a higher level contains a sub-network

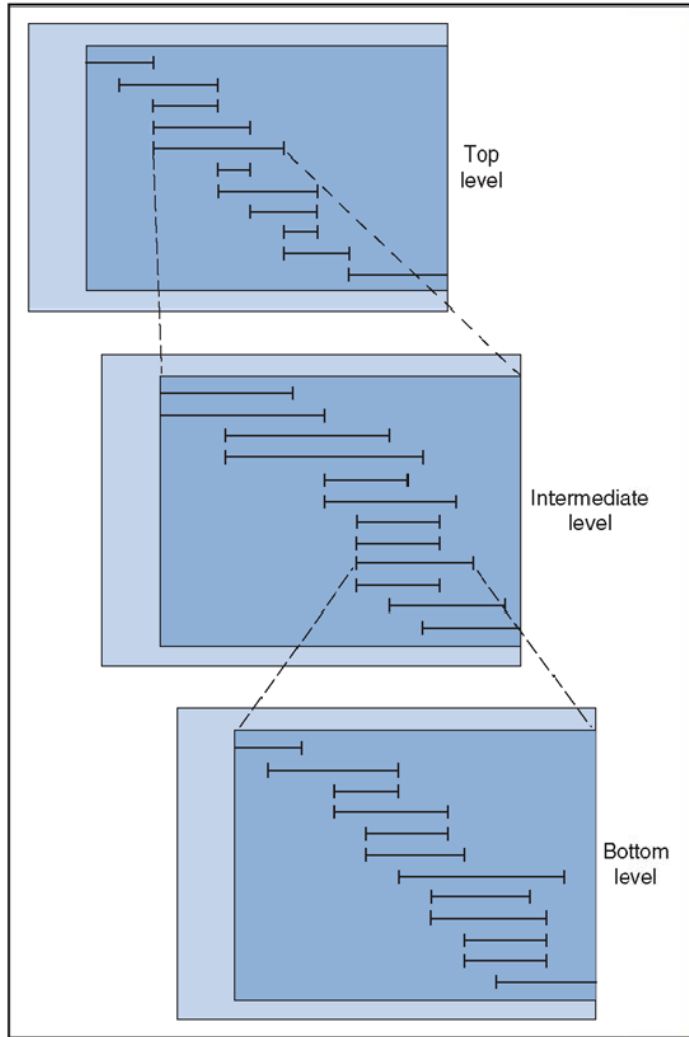

AON (cont'd)

In large projects, good practice is that AON networks have only one start and one end node

If the project does not have a single end node (or a single start node), insert a dummy activity

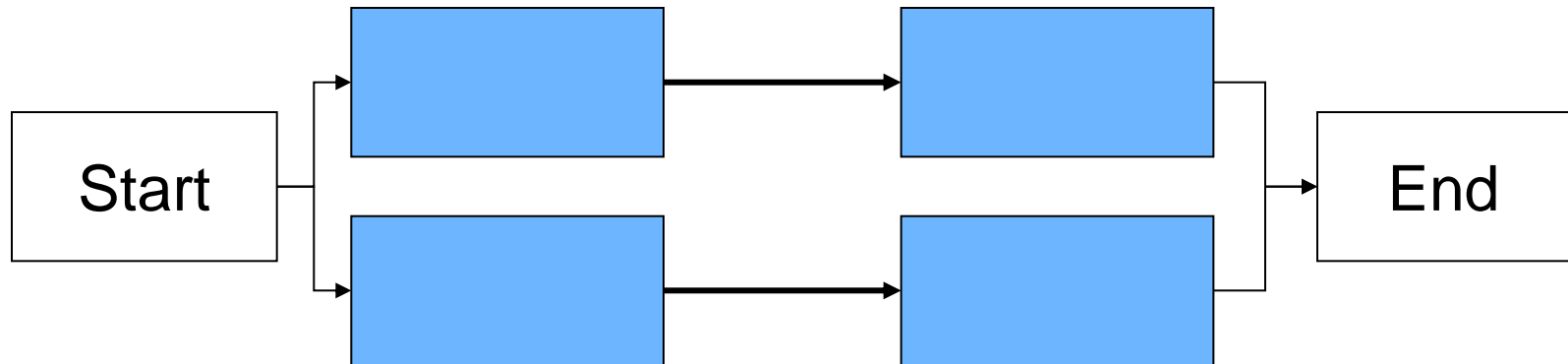

Activity-On Arrow (AOA)

- AOA: “Activity on Arrow”
- Each *activity* is represented by *an arrow*, with nodes at each end to represent the start and finish of the activity

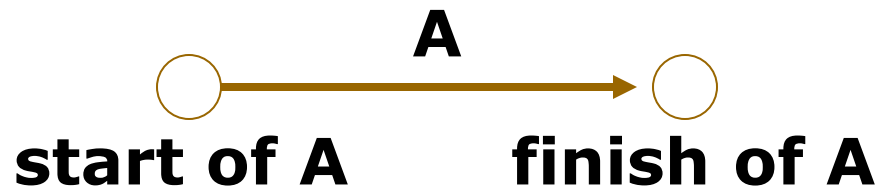

AOA networks are more similar to Gantt charts than AON networks but they necessitate the use of dummy activities

AOA and Dummy Activities

Page 244

Convert the following AON diagram into AOA:

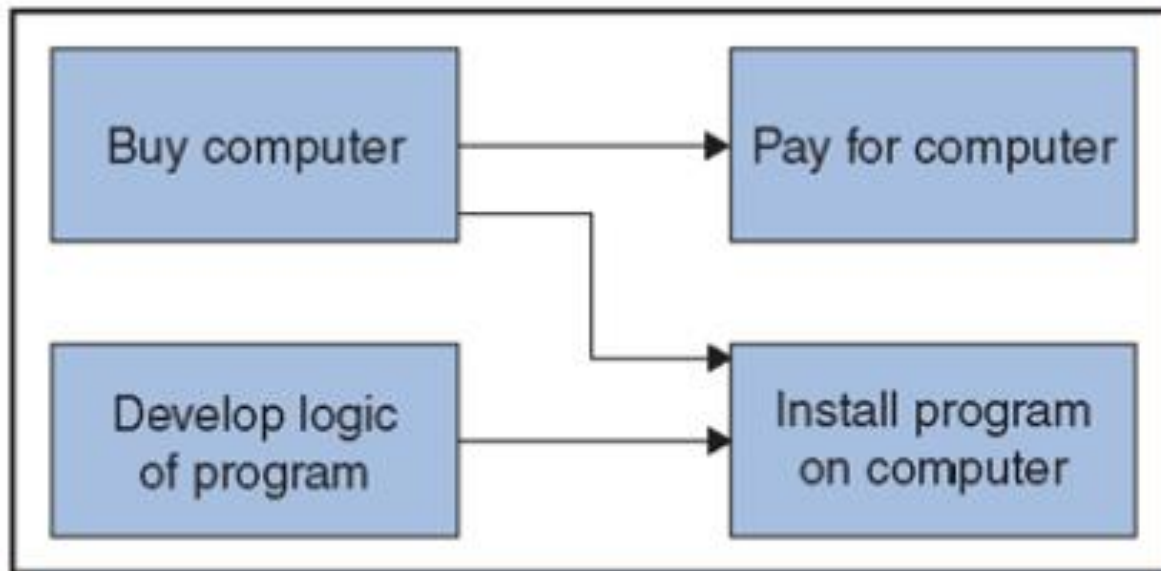

Figure 6-31
AON diagram.

AOA and Dummy Activities

Page 244

AOA diagram requires a dummy activity:

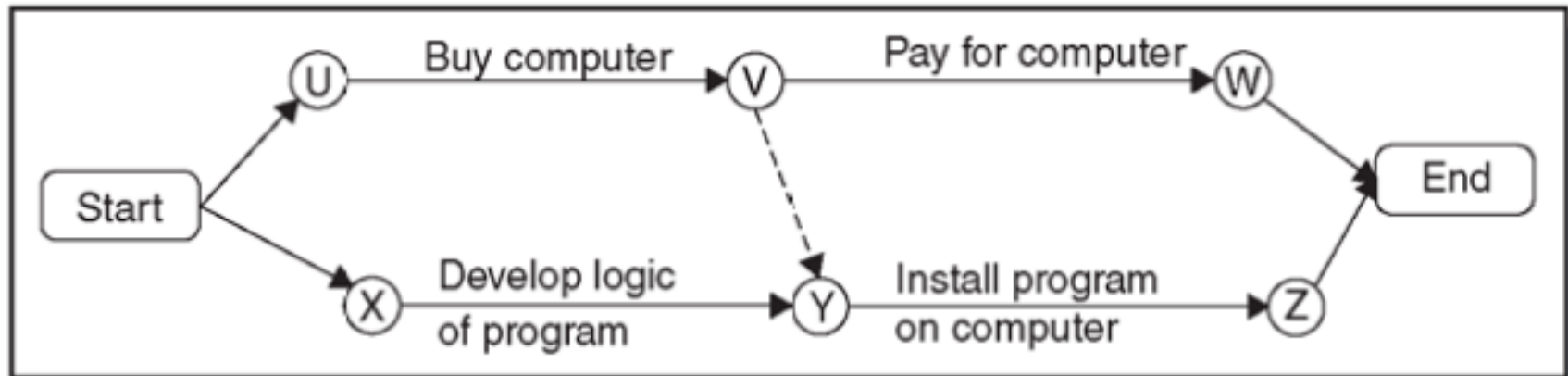

Figure 6-32

AOA and Dummy Activities

Dummy Activities

- Are used to show predecessor relationships
 - Are called “dummies” because they are not real activities and involve no work.
-

AON and AOA

- Both AON and AOA kinds of networks are used in industry but AON has become more popular
 - We will therefore use AON
-

AON: Example (Illustrative only)

Page 213

Figure 6-1

Logic diagram for getting up and getting dressed.

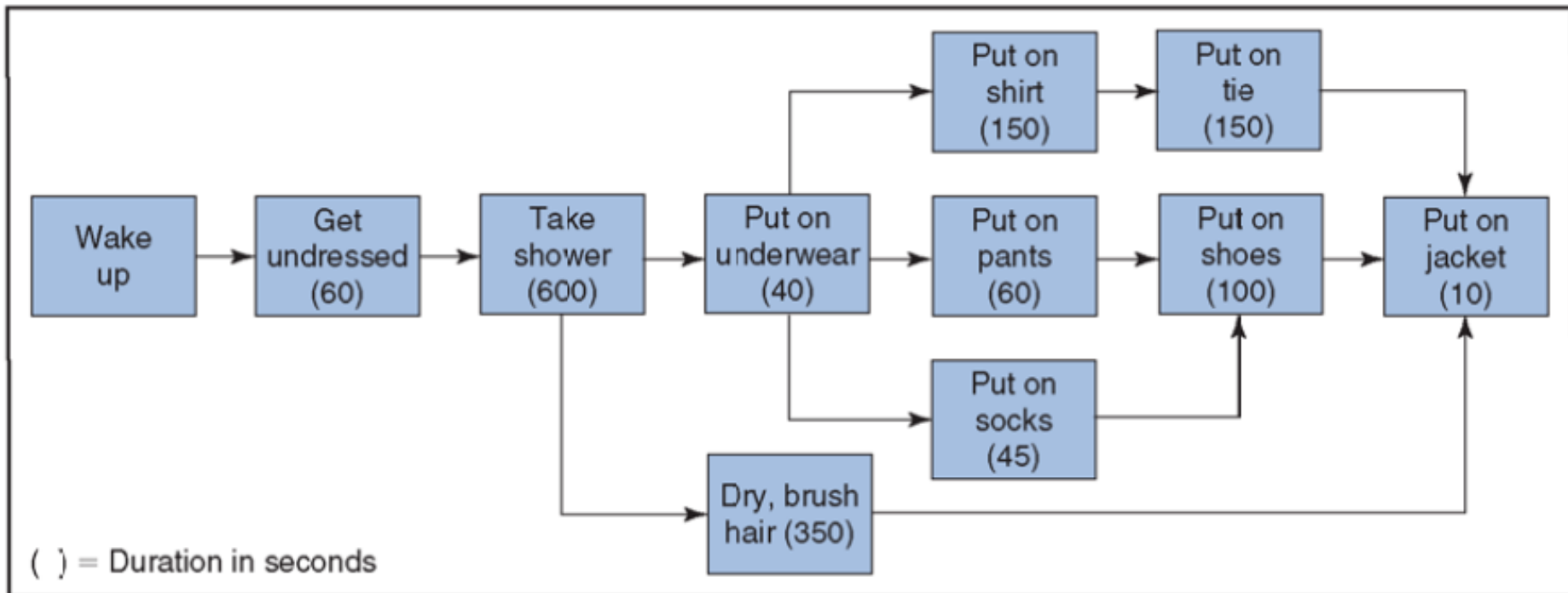

AON: Types of Dependencies

Page 214

- Mandatory – impossible to reverse sequence
 - Discretionary – can delete dependency to fast track project
 - External – dependent on some event external to the project
-

AON: Types of Dependencies

Which ones are mandatory which ones are discretionary?

Figure 6-1

Logic diagram for getting up and getting dressed.

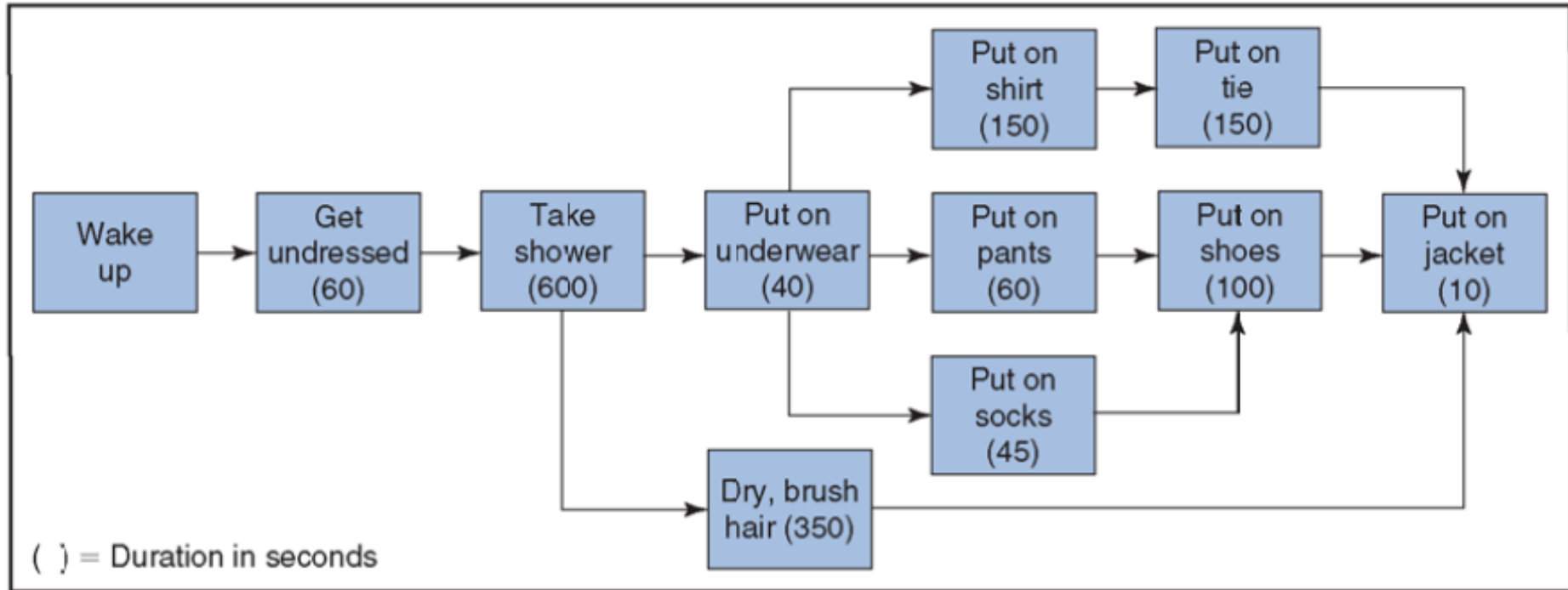

It's not about the necessity of the activity, but about the sequence

Class Exercise: Draw an AON Network for the Following:

ACTIVITY	IMMEDIATE PREDECESSOR
A	—
B	A
C	A
D	B, C
E	B, C

AON: Consider a specific Activity

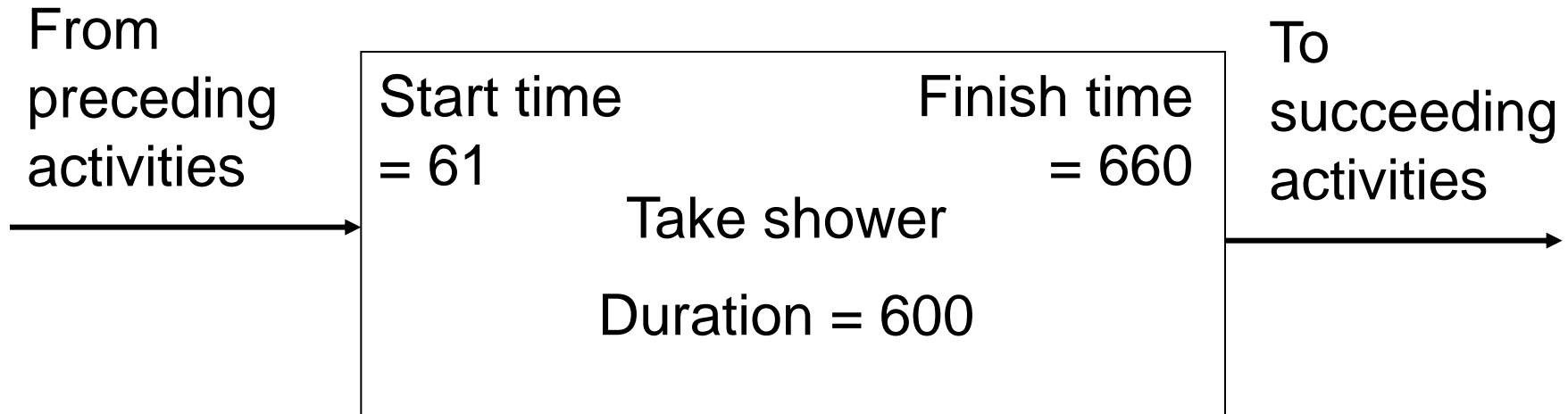

$$\text{End date} = \text{Start date} + \text{duration} - 1$$

Why minus 1?

Why minus 1?

Consider a 5-day activity starting on Monday the 1st of the month:

Monday = Day 1 = Start date

Friday = Day 5 = Finish date

Duration = 5

End date = Start date + duration - 1

The assumption is that the activity starts Monday morning early and finishes late Friday afternoon

Determining Earliest Times for Activities

Forward Pass:

“The calculation of the early start and early finish dates for the uncompleted portions of all network activities”

— PMBOK

Forward Pass

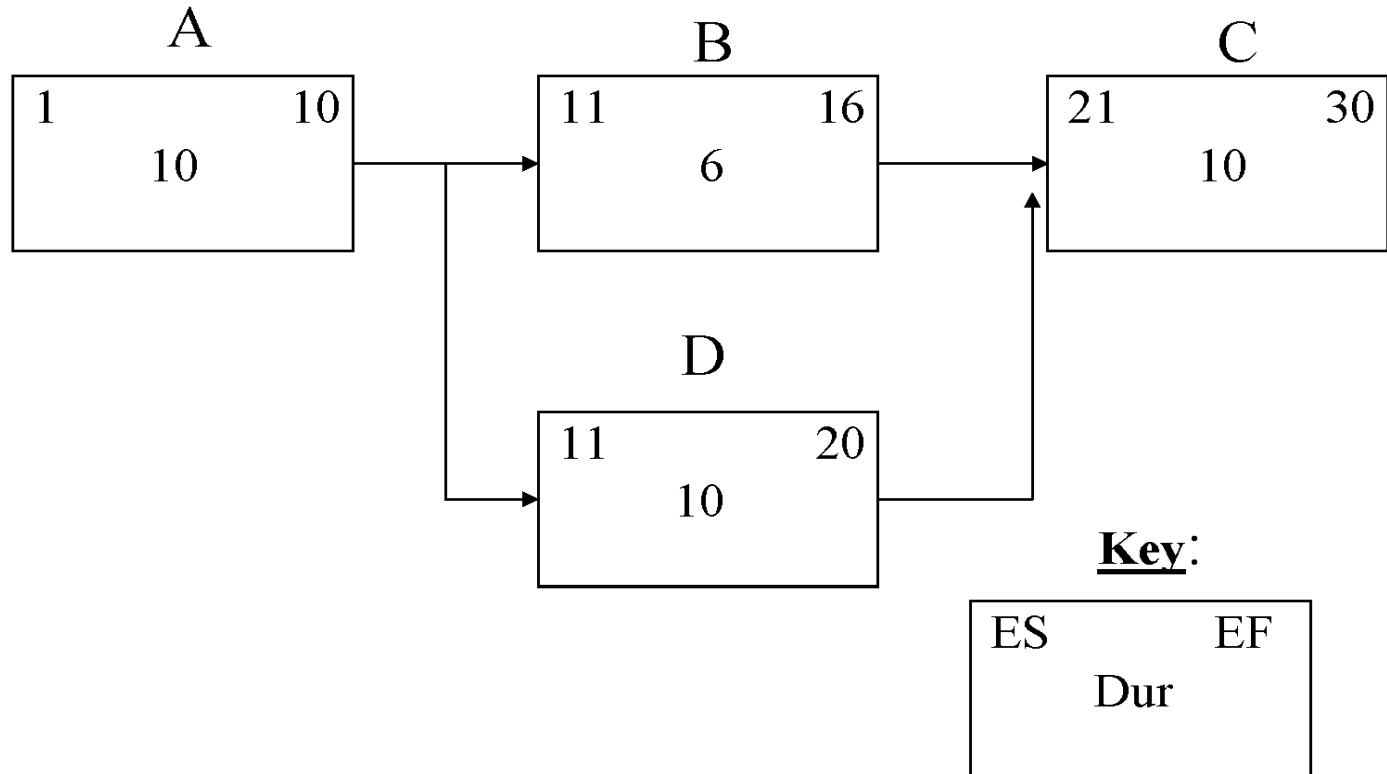

ES = Early start (forward pass)
EF = Early finish (forward pass)
Dur = Duration (days)

Finish date = Start date + duration - 1

Forward Pass

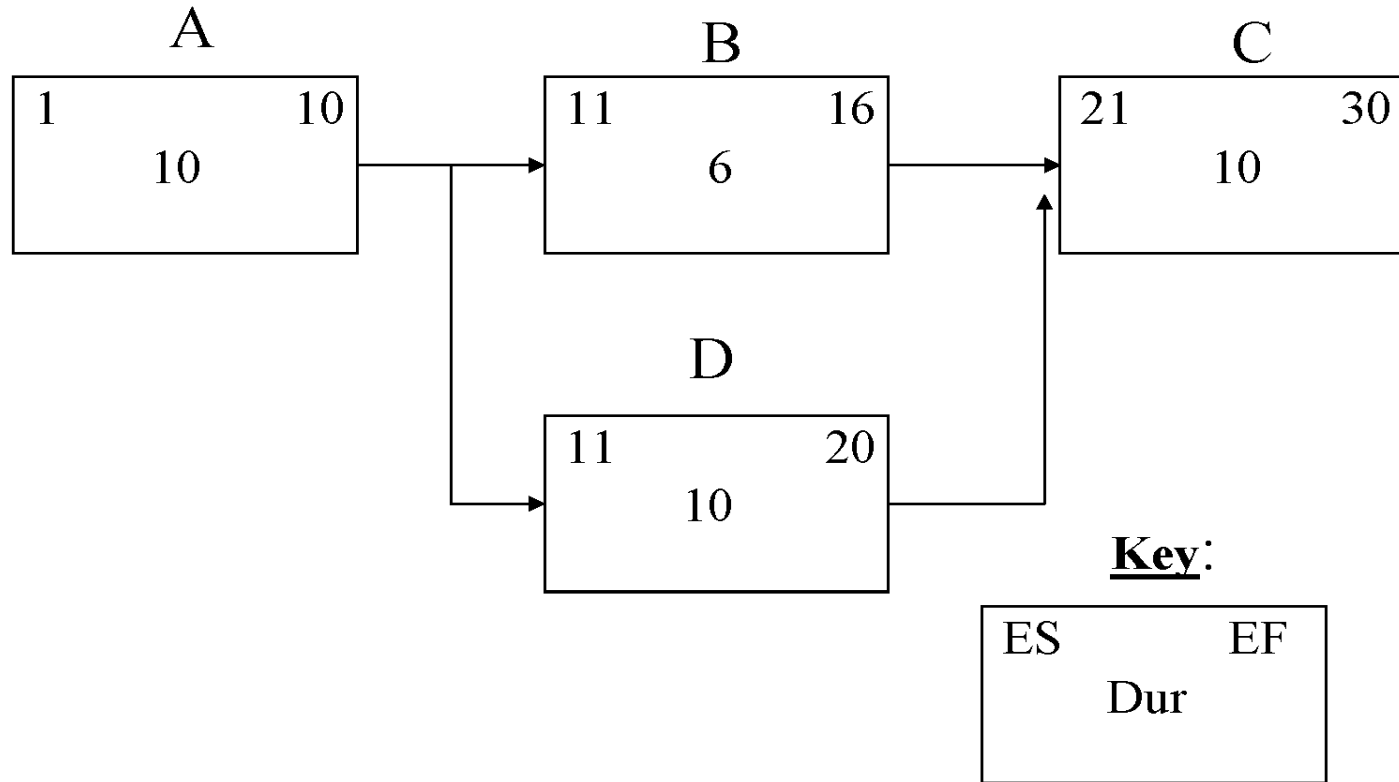

When an activity has more than one predecessor, (like Activity C) use *the latest* predecessor to determine the early start date

Forward Pass: Class Exercise

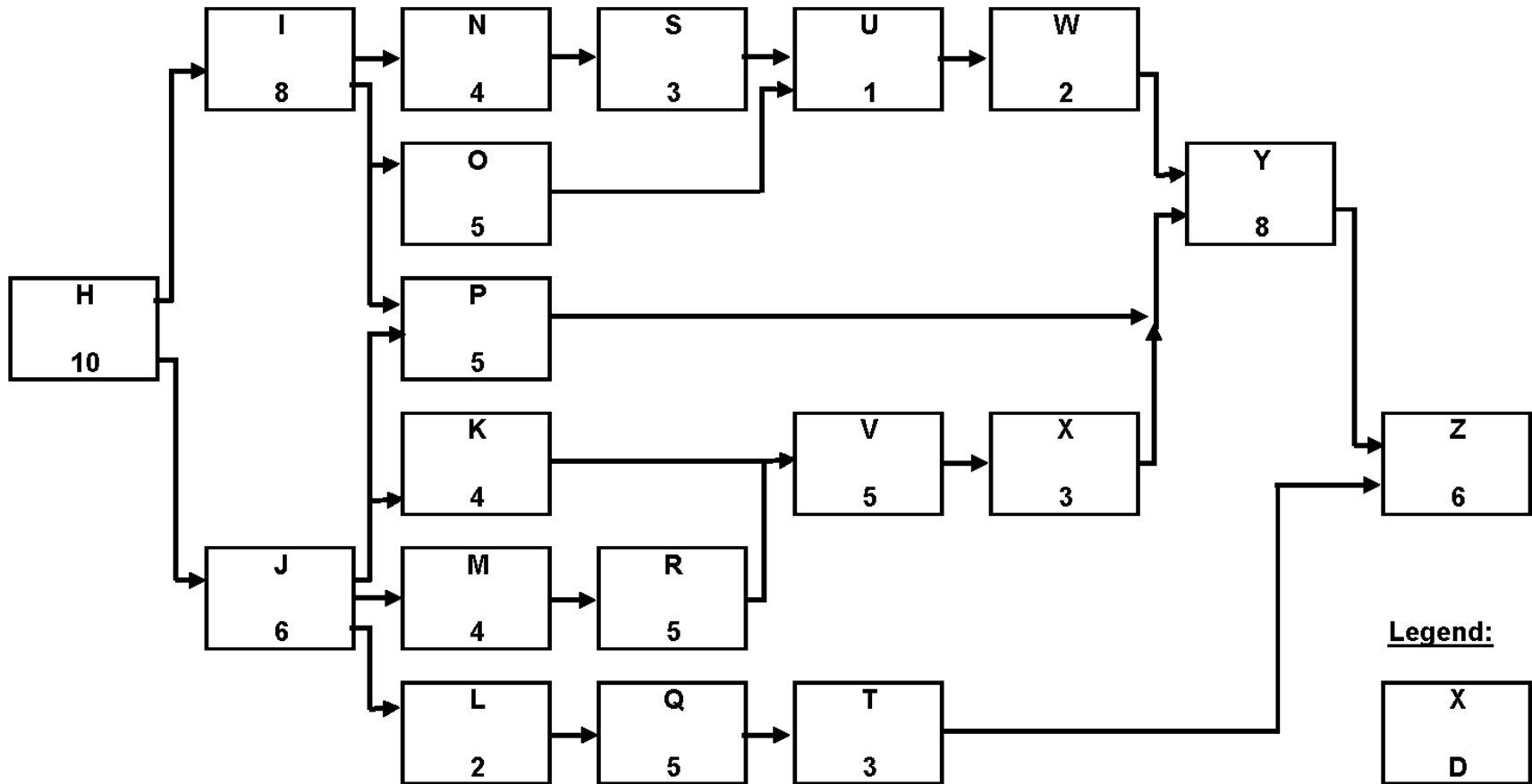

Legend:

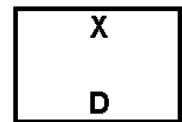

X = Activity code
D = Duration in weeks

Determining Latest Times for Activities

Backward Pass:

“The calculation of the late finish dates and late start dates for the uncompleted portions of all schedule activities. Determined by working backwards through the schedule network logic from the project’s end date. The end date may be calculated in the forward pass or determined by the customer or sponsor”

—PMBOK

Backward Pass

Early Finish = Early Start + duration – 1

Late Start = Late Finish – Duration + 1

$$\text{Late Start} = \text{Late Finish} - \text{Duration} + 1$$

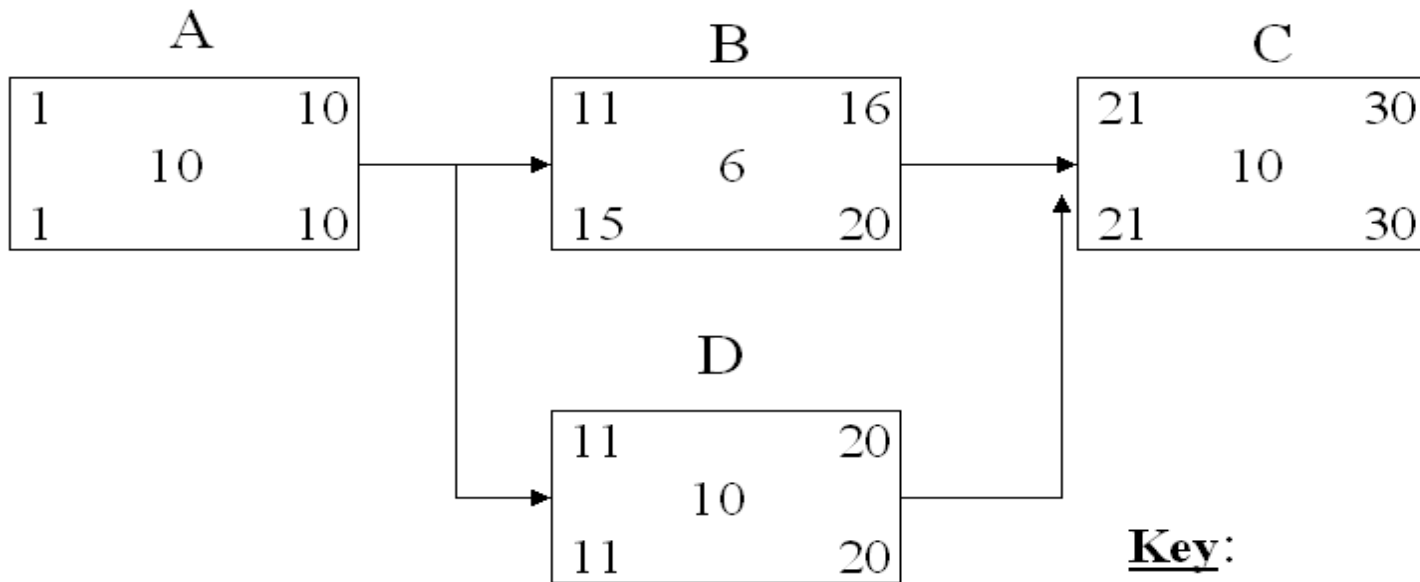

ES = Early start (forward pass)
 EF = Early finish (forward pass)
 LF = Late finish (backward pass)
 LS = Late start (backward pass)
 Dur = Duration (days)

Backward Pass

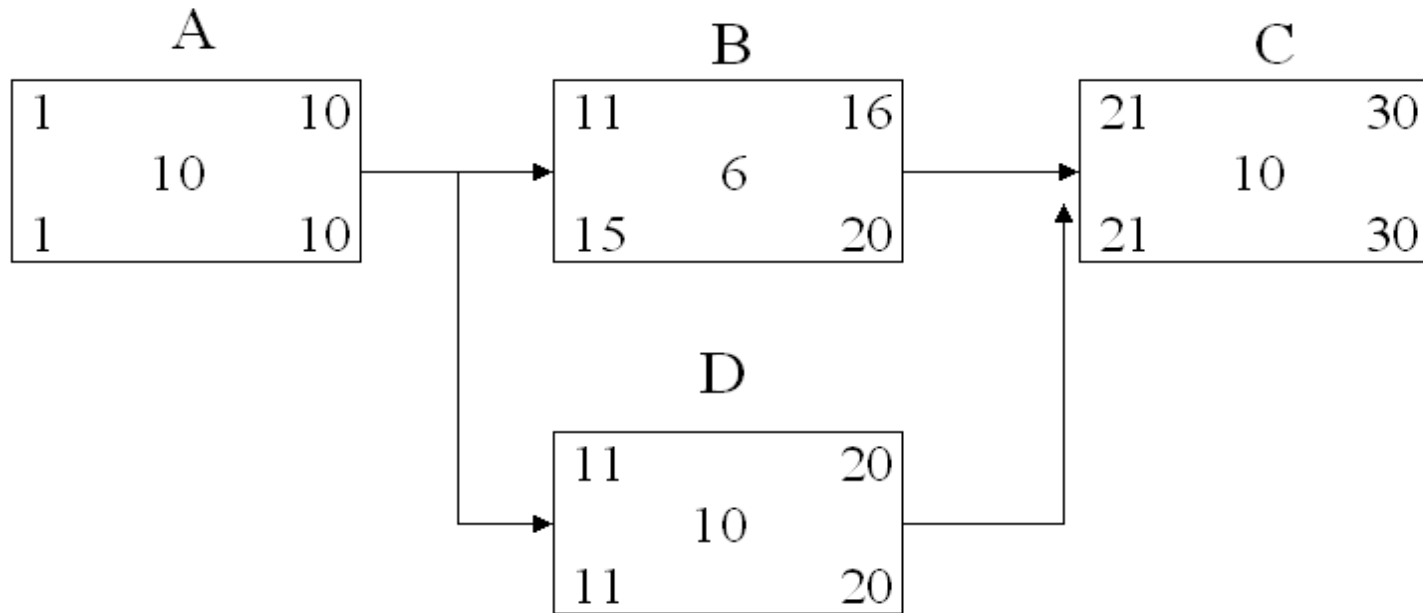

When an activity has more than one successor, (like Activity A) use the earliest start date to determine the late finish date of the predecessor (i.e. **A finishes at day 10, not 14**)

Backward Pass: Class Exercise

Page 222

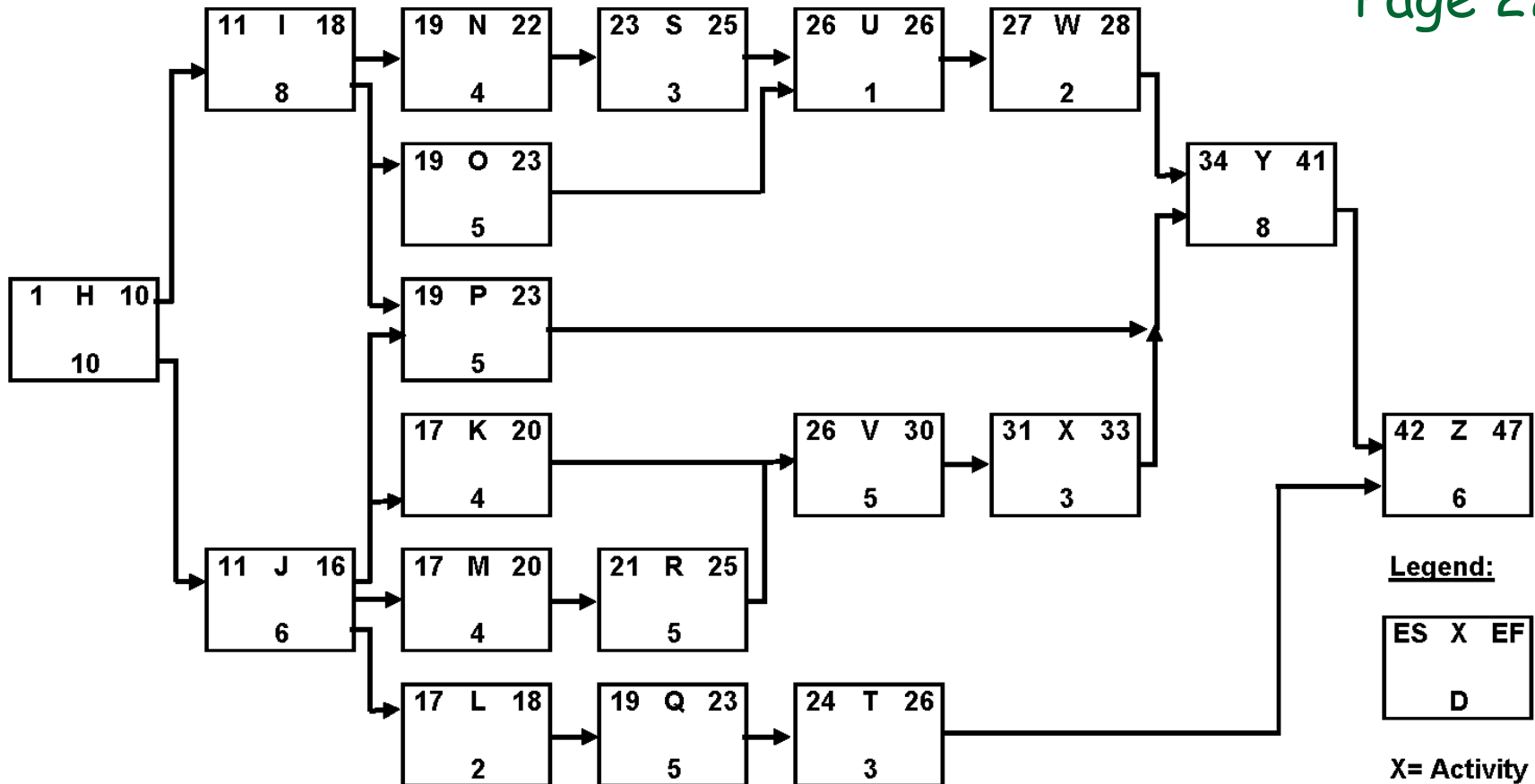

X= Activity code
D = Duration in weeks
ES = Early Start
EF = Early Finish

Due Date set by Customer

If a project has to be done ASAP, use the end date calculated during the forward pass.

If a project has a predetermined due date, use this due date instead of the date calculated during the forward pass

Due Date set by Customer

Project with predetermined due date, Day 40

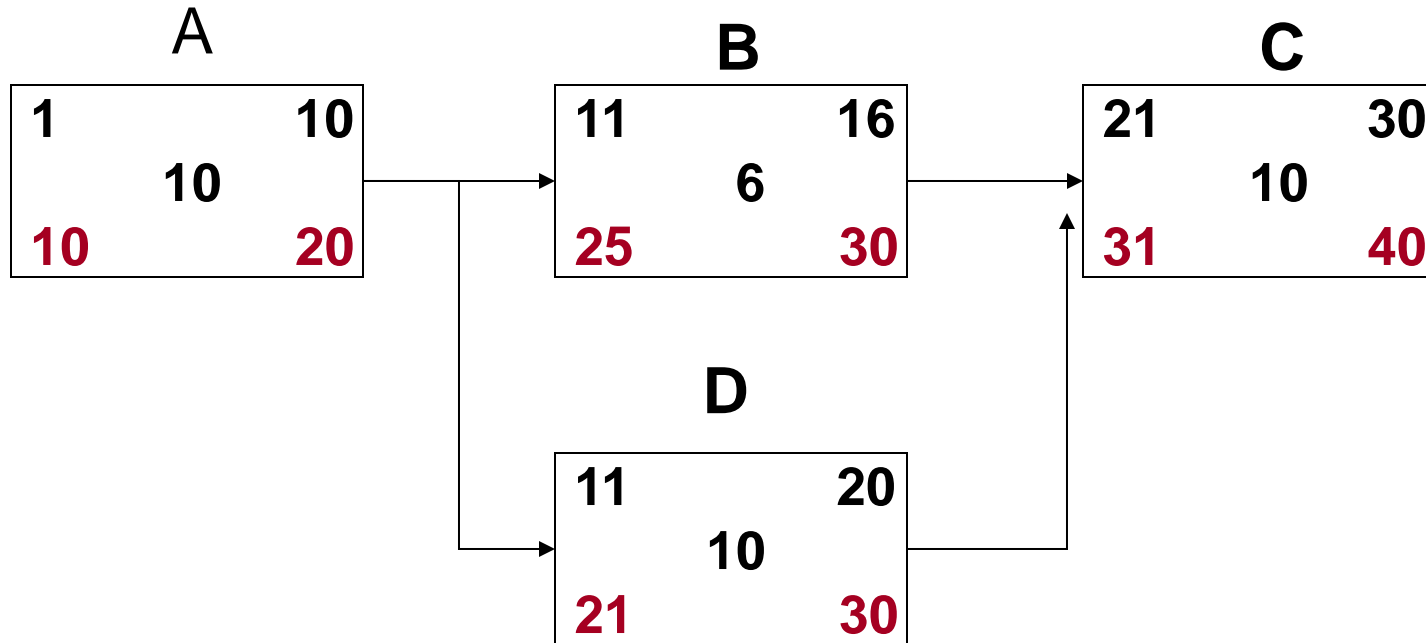

Critical Path

The longest path through a network
(from start to finish)

Activities on the Critical Path are called
“critical activities”

Critical Path

- Why is it an important concept?
 - Determines the project duration
 - Shows the project manager where to focus her attention (critical activities have least flexibility)
-

The Critical Path is Not Stable

“The critical path will generally change from time to time as activities are completed ahead or fall behind schedule”

—PMBOK, PMI 1996

And it does so without warning!



You do not know where to focus

(Solutions to this problem discussed later)

Total Slack (Float)

Page 224

$$\text{Total Slack} = \text{LS} - \text{ES}$$

$$= \text{LF} - \text{EF}$$

Total Slack = Total Float (or simply “Float”)

Slack Implies Early and Late Times

Start Finish Late Start Late Finish

ID	Task Name	Start	Finish	Late Start	Late Finish	Free Slack	Total Slack	2006														
								A	M	J	J	A	S	O	N	D	J	F	M	A		
1	Basic design	Mon 5/16/05	Tue 7/26/05	Mon 5/16/05	Tue 7/26/05	0 wks	0 wks															
2	Hardware design for "A"	Wed 7/27/05	Wed 9/21/05	Wed 8/31/05	Wed 10/26/05	0 wks	5 wks															
3	Hardware design for "B"	Wed 7/27/05	Wed 9/7/05	Wed 7/27/05	Wed 9/7/05	0 wks	0 wks															
4	Drawings for B	Thu 9/8/05	Wed 10/5/05	Thu 10/13/05	Wed 11/9/05	5 wks	5 wks															
5	Software specifications	Thu 9/8/05	Wed 9/21/05	Mon 2/6/06	Fri 2/17/06	0 wks	21 wks															
6	Parts purchase for B	Thu 9/8/05	Wed 10/5/05	Thu 9/8/05	Wed 10/5/05	0 wks	0 wks															
7	Parts purchase for A	Thu 9/22/05	Wed 10/19/05	Thu 10/27/05	Wed 11/23/05	0 wks	5 wks															
8	Drawings for A	Thu 9/22/05	Wed 10/26/05	Thu 11/10/05	Wed 12/14/05	2 wks	7 wks															
9	Installation drawings	Thu 9/22/05	Wed 10/26/05	Thu 12/1/05	Fri 1/6/06	10 wks	10 wks															
10	Software Purchases	Thu 9/22/05	Wed 10/26/05	Mon 2/20/06	Fri 3/24/06	0 wks	21 wks															
11	Delivery of parts for A	Thu 10/6/05	Wed 11/9/05	Thu 10/6/05	Wed 11/9/05	0 wks	0 wks															
12	Delivery of parts for B	Thu 10/20/05	Wed 11/9/05	Thu 11/24/05	Wed 12/14/05	0 wks	5 wks															
13	Software delivery	Thu 10/27/05	Wed 11/16/05	Thu 12/15/05	Fri 1/6/06	7 wks	7 wks															
14	Assembly of A	Thu 11/10/05	Wed 11/16/05	Thu 12/15/05	Wed 12/21/05	0 wks	5 wks															
15	Assembly of B	Thu 11/10/05	Wed 12/14/05	Thu 11/10/05	Wed 12/14/05	0 wks	0 wks															
16	Test A	Thu 11/17/05	Wed 11/30/05	Thu 12/22/05	Fri 1/6/06	5 wks	5 wks															
17	Test B	Thu 12/15/05	Fri 1/6/06	Thu 12/15/05	Fri 1/6/06	0 wks	0 wks															
18	Final Installation	Mon 1/9/06	Fri 3/3/06	Mon 1/9/06	Fri 3/3/06	0 wks	0 wks															
19	Final Test	Mon 3/6/06	Fri 4/14/06	Mon 3/6/06	Fri 4/14/06	0 wks	0 wks															

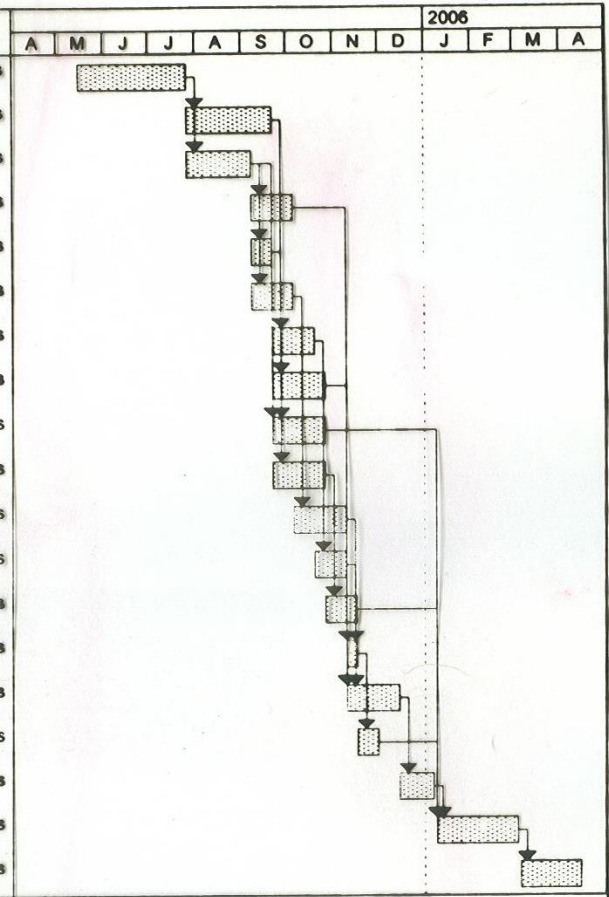

Slack (cont'd)

Slack represents scheduling flexibility

- ❑ How much later than early start time is permissible
 - ❑ How much an activity can exceed expected duration
 - ❑ Some activities cannot be delayed by any amount (zero slack). This is often the case on the critical path
-

Slack on the Critical Path

Predetermined due date later than the earliest possible completion

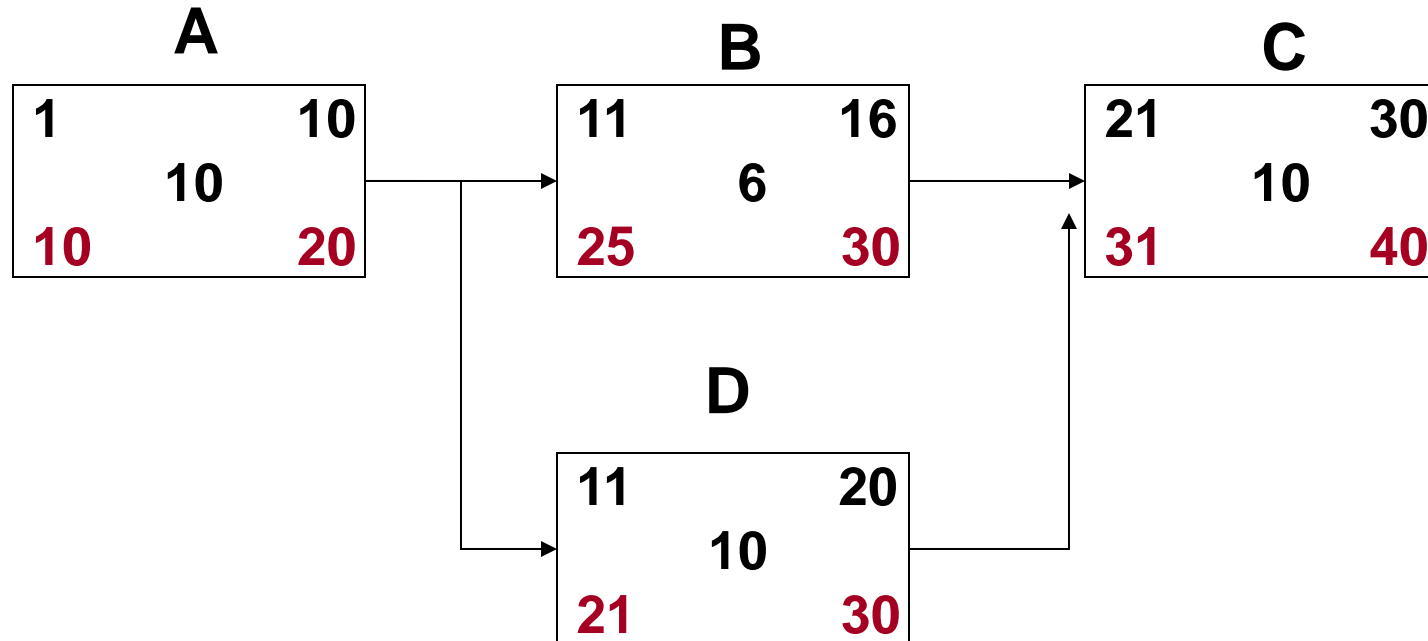

In this case there is float on the critical path

Activities with Slack

Should activities with slack be performed as soon as possible or only later?

Class Discussion:

- ❑ Read Review Question No. 16 (Page 250)
 - ❑ Make notes (individually)
 - ❑ Discuss with people sitting next to you
 - ❑ Verdict?
-

Slack

Why should the Gantt chart be drawn only after the network has been developed?

For each activity with float, a decision has to be made whether the activity should be performed ASAP or only later

Free Slack (Free Float)

- Total slack is late times minus early times, and is amount of time an activity can be delayed *without delaying project*
 - Free slack is amount of time an activity can be delayed *without delaying at least one other activity*
 - If an activity is delayed more than the free slack, it will delay successors that are scheduled as early as possible and that could be disruptive
-

Free Slack

What is the free slack of Activity X?

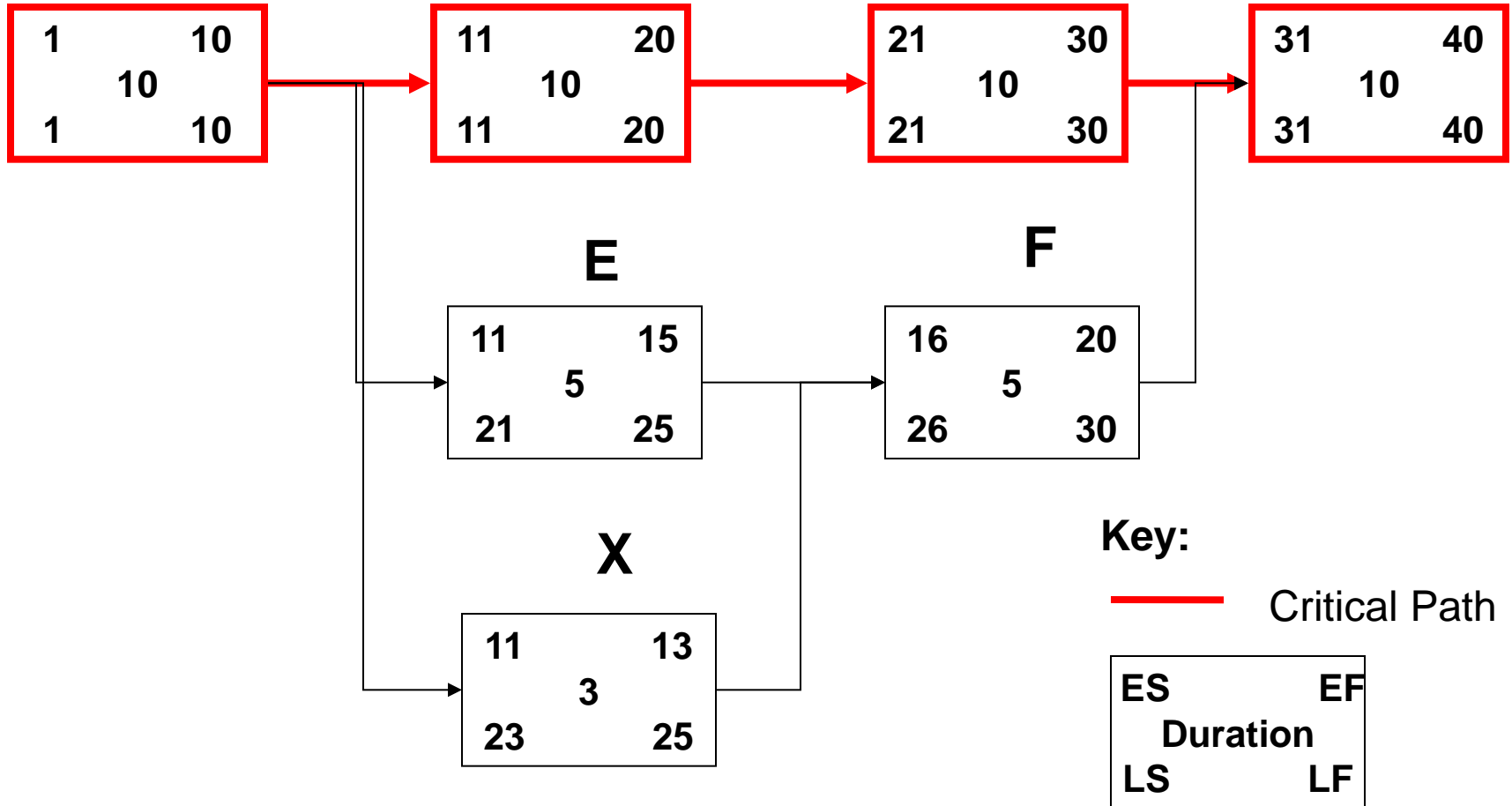

Free Slack

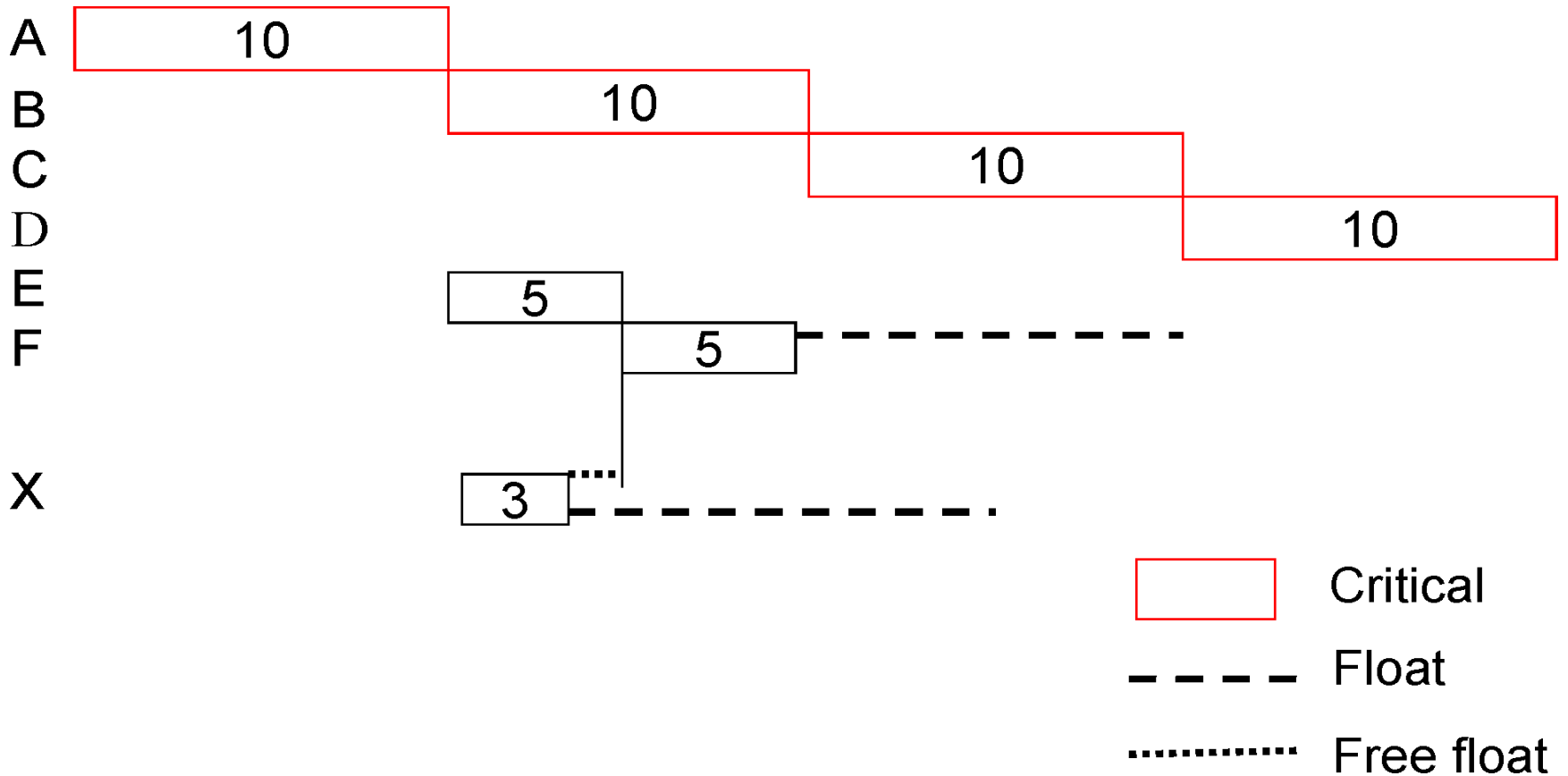

Free float of Activity X = 2 days. If delayed for more than 2 days, from its early start, X will delay the early start of a successor.
Float of Activity X = 12 days. After that it will delay the project.

Summary of Planning Process

- List stakeholders
- Determine project scope with stakeholders
- Develop WBS to identify schedule activities
- Draw table indicating predecessors (See Table 6-2, Table 6-3, Table 6.4). Using the table helps to ensure that no necessary dependencies are overlooked
- Draw network diagram
- Do forward and backward pass to determine critical path and slack
- Decisions regarding early and late start of activities
- Draw Gantt chart

Summary of Planning Process

Only in the case of a very simple and small project should you start the scheduling process by drawing a Gantt chart!

Scheduling Process

Computerized planning systems develop the following three items concurrently:

- ❑ Table indicating predecessors
 - ❑ Network
 - ❑ Gantt chart
-

Calendar Schedules

The schedule has to be converted to indicate calendar dates (and non-working days e.g. weekends need to be taken into account)

Computerized systems perform this function well

Calendar Schedule: Example

Page 227

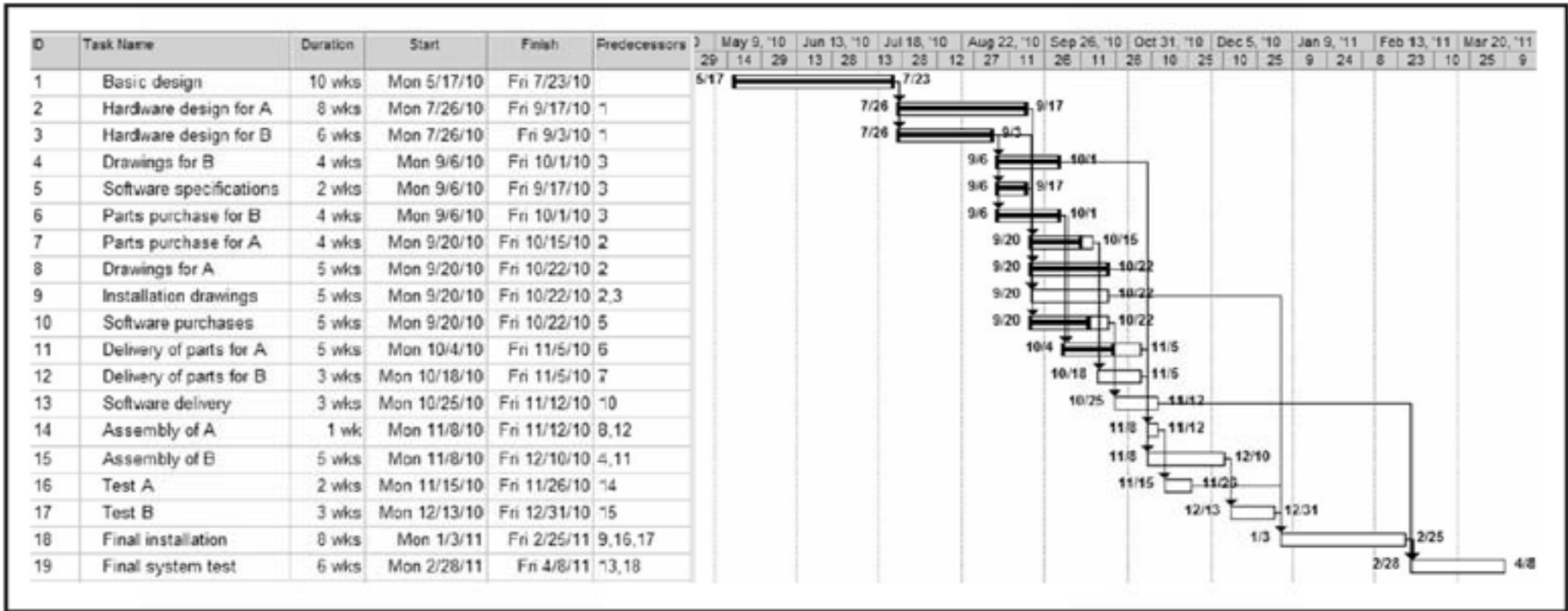

Figure 6-9

LOGON project schedule adjusted for holidays and weekends.

Converting from Network to Calendar Schedule

Page 227

Considerations:

- ❑ Resource constraints (discussed later)
 - ❑ Risk of changes
 - ❑ Cash flow
 - ❑ Logistics
-

Precedence Diagramming

- Until now we assumed that a successor activity can start as soon as all predecessor activities have been completed (and that it *must* start then)
 - Sometimes we want the successor to be delayed somewhat (or expedited) from the end date of a predecessor
 - Lag and lead relationships are used in such cases
-

Precedence Diagramming

Page 230

A 5-day lag between predecessor and successor:

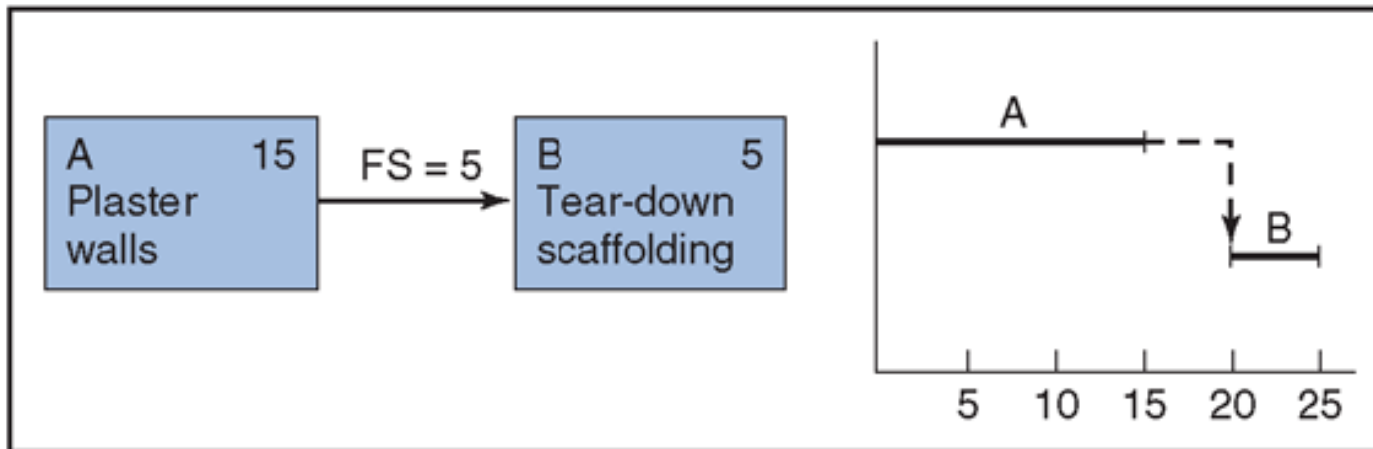

Figure 6-15

A lead between the predecessor and successor would imply an overlap

Precedence Diagramming and Conventions other than Finish-to-Start

Start-to-start relationship:

Page 229

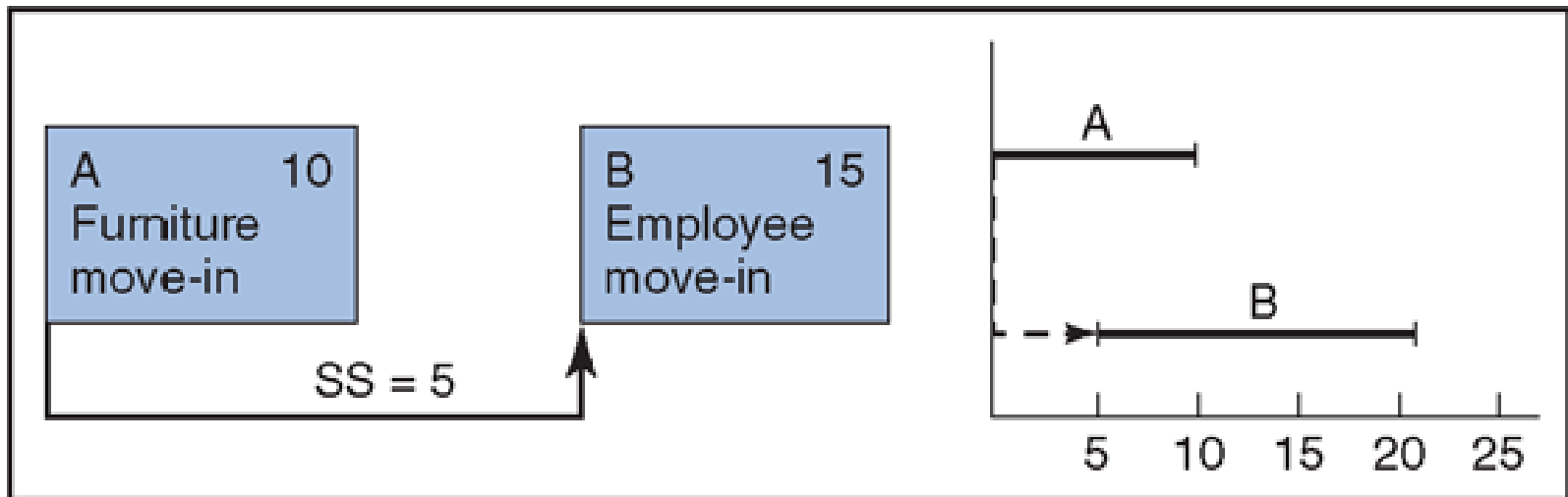

Figure 6-12
Example of SS relationship.

Precedence Diagramming and Conventions other than Finish-to-Start

Finish-to-finish relationship:

Page 229

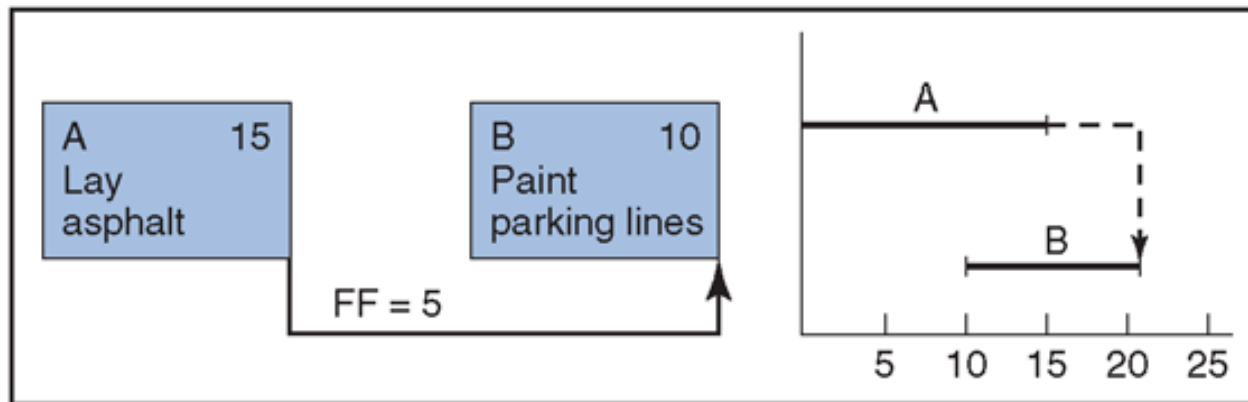

Figure 6-13
Example of FF relationship.

Mostly used with zero lag where activities must end on the same day

Precedence Diagramming and Conventions other than Finish-to-Start

Start-to-finish relationship:

Page 229

Figure 6-14

Example of SF relationship.

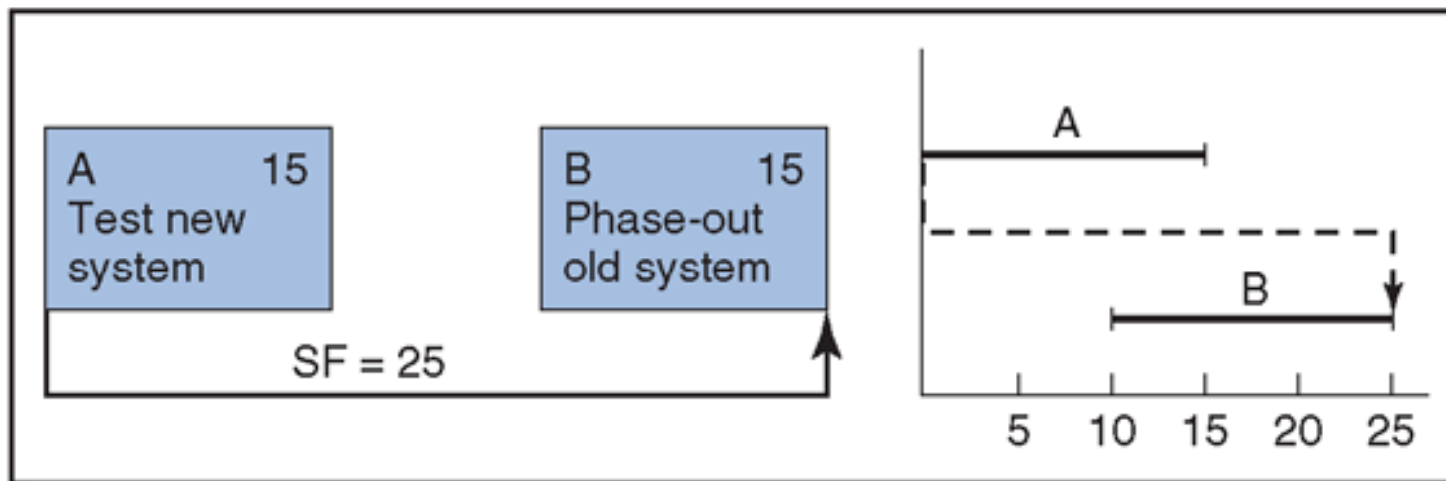

Scheduling with Resource Constraints

Page 233

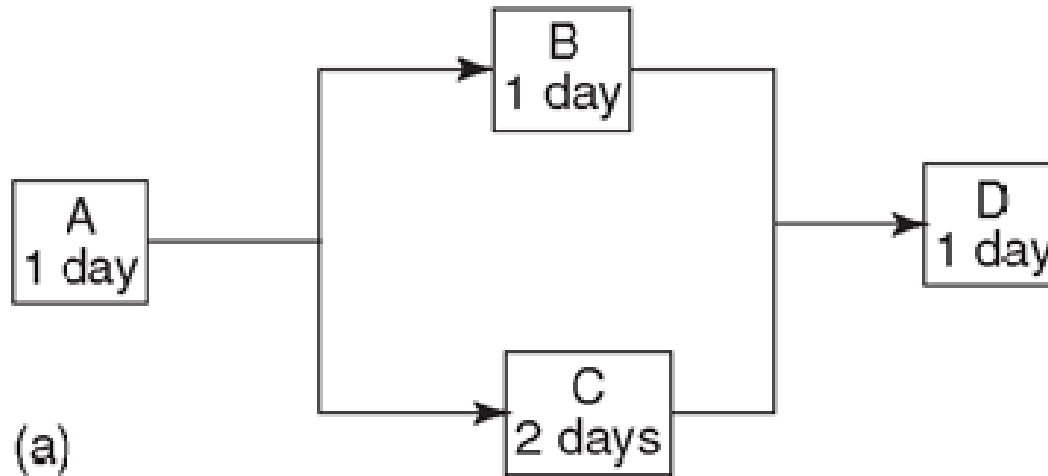

(b)

	Day 1	Day 2	Day 3	Day 4	Day 5
A	█				
B		█			
C		█	█		
D				█	

Diagram (b) shows a resource allocation chart for the project. The chart is organized into a grid with columns for Day 1 through Day 5 and rows for tasks A, B, C, and D. Task A is scheduled for Day 1. Task B is scheduled for Day 2. Task C is scheduled for Day 2 and Day 3. Task D is scheduled for Day 4. The total duration of the project is 4 days.

Project can theoretically be done within 4 days

Scheduling with Resource Constraints

If Activity B and Activity C have to be done by the same resource, the project will take longer

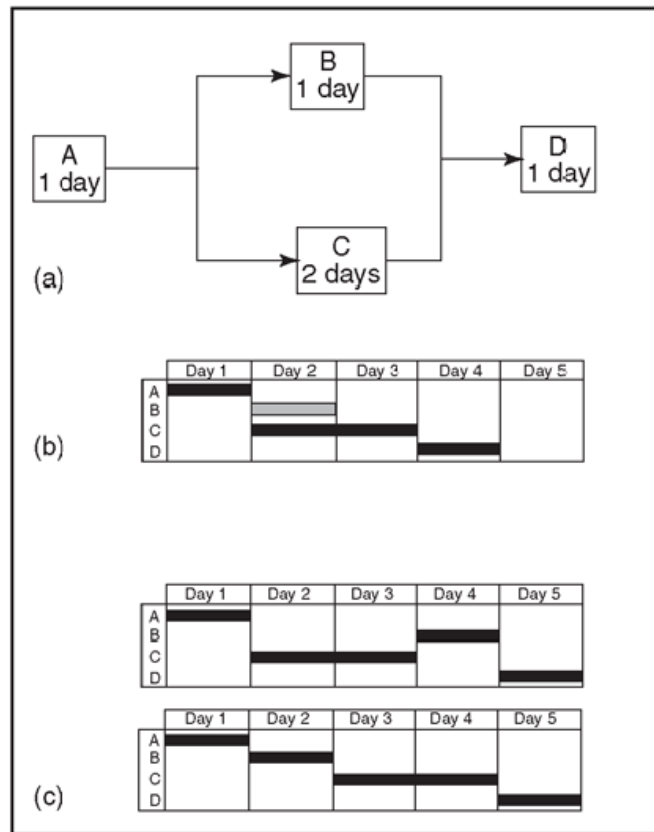

Page 233

Figure 6-22
The effect of a constrained resource on schedule.

Scheduling with Resource Constraints: Workload

Workload of an individual can be indicated

- ❑ in man-hours required
- ❑ in % of time (man-hours) available

Workload of a facility / company / division
can be indicated in number of workers
required

Scheduling with Resource Constraints

Class Exercise

Solve Review Problem No 20
on Page 251

Scheduling with Resource Constraints: Resource Leveling

Resource Leveling:

“Any form of schedule network analysis in which scheduling decisions (start and finish dates) are driven by resource constraints (e.g. limited resource availability or difficult-to-manage changes in resource availability levels).”

PMBOK

Resource Leveling of a Time-Constrained Project

Figure 6-23
Schedule and corresponding worker loading for the LOGON project.

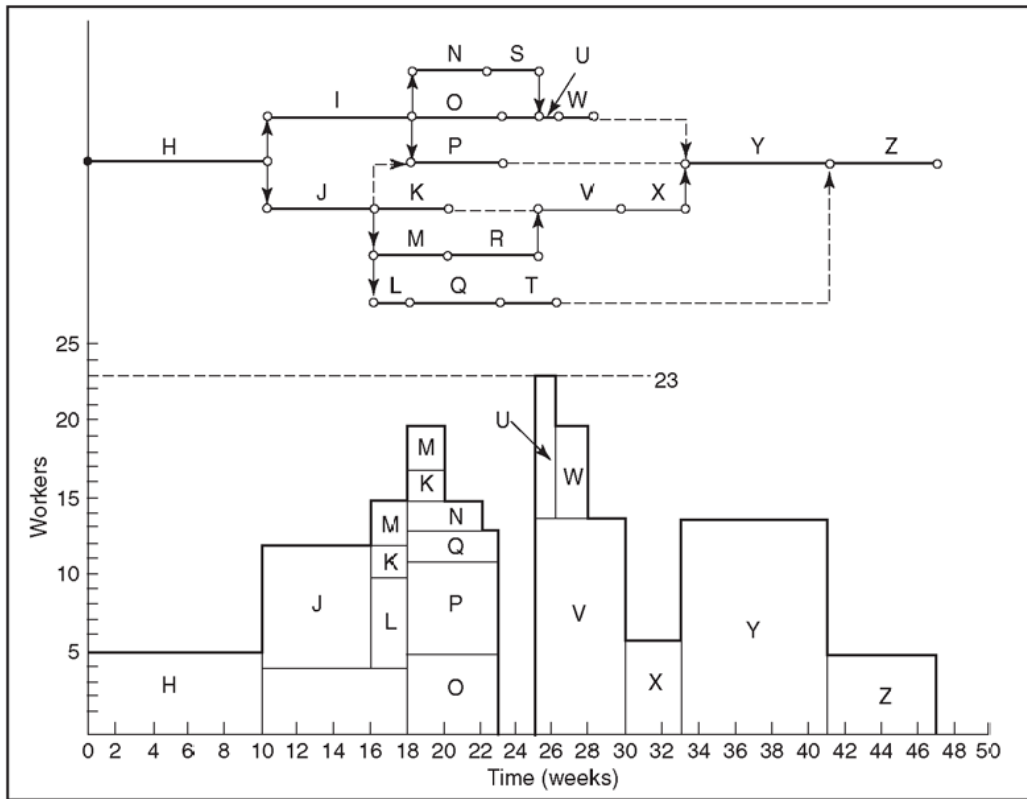

Fluctuations in workload difficult to manage

Use float (dotted lines) to reduce fluctuations

Resource Leveling of a Time-Constrained Project

Figure 6-24
Smoothed worker loading for the LOGON project.

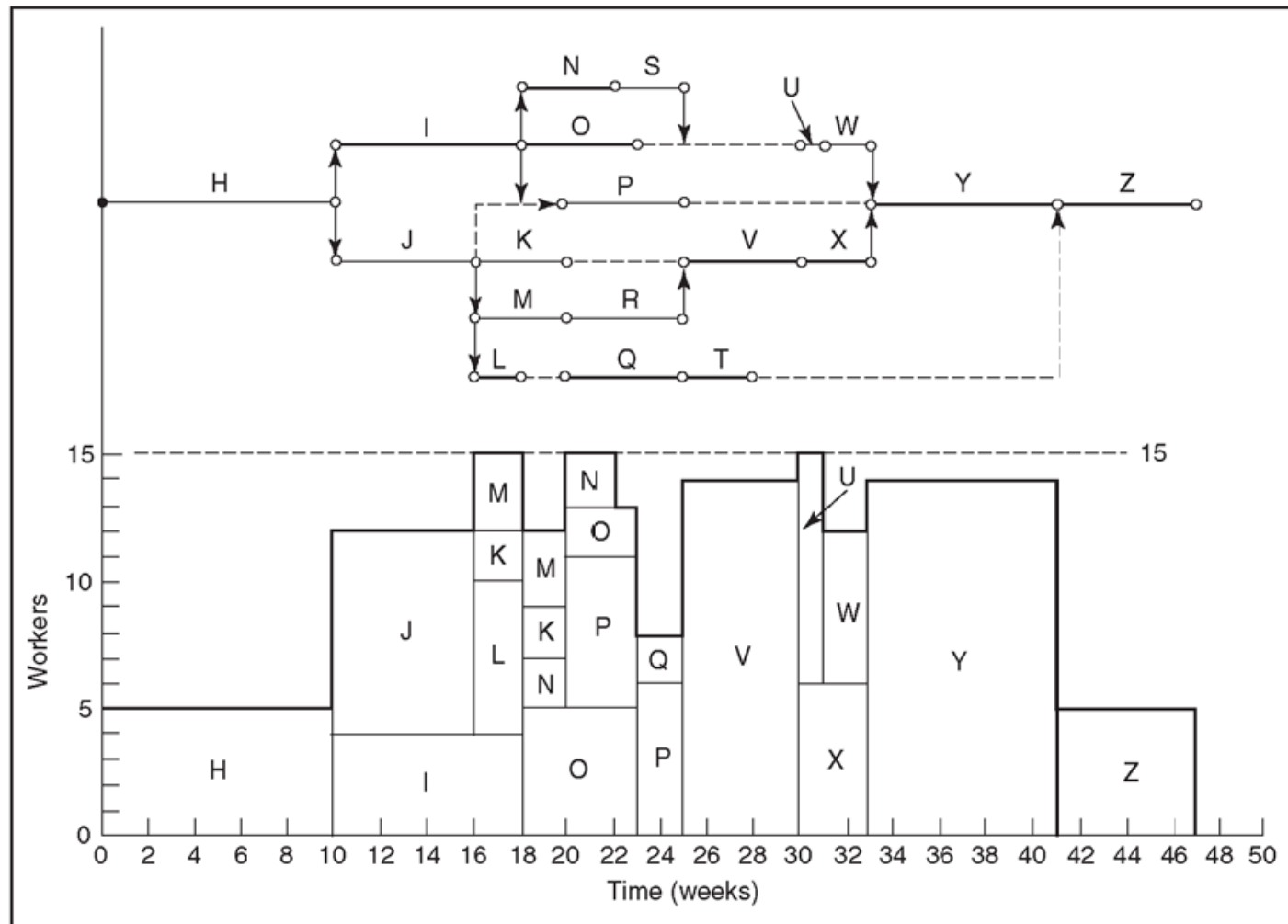

Resource Leveling of a Time-Constrained Project

Class Assignment:
Discuss Review Problem 24 on
pages 251 - 252

During resource leveling activities can be split (to “jump” between activities) but it often has a negative effect:

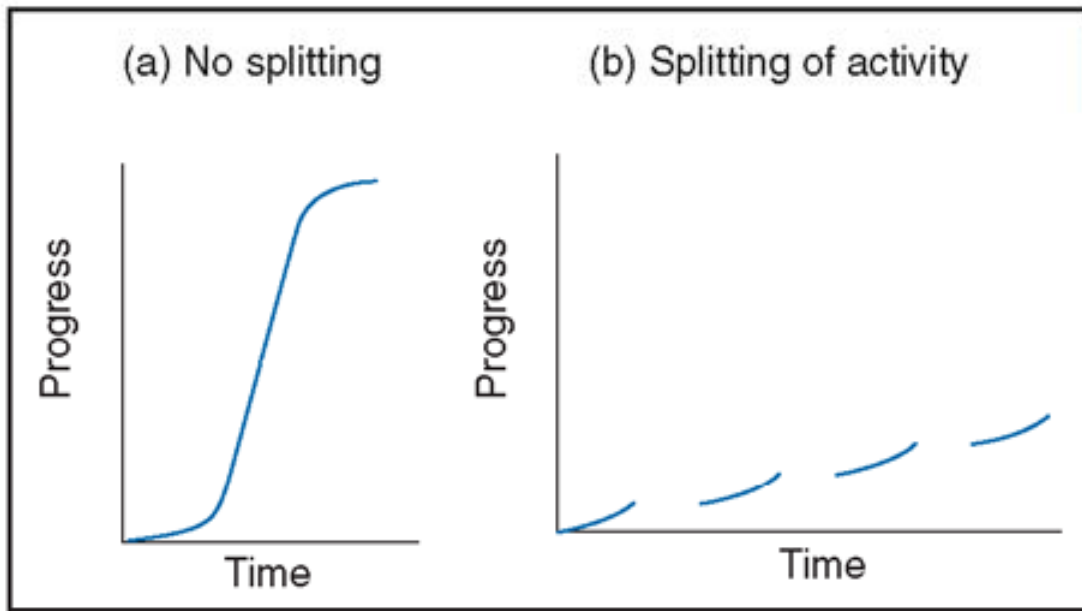

Figure 6-25
The effect of splitting of an activity on duration.

Resource Leveling: Multiple Resources

Reducing overload or improving difficult-to-manage fluctuations in workload of one resource sometimes leads to overloading or more fluctuations in workload of other resources

Resource Leveling of a Resource-Constrained Project

When the maximum availability of a resource is a constraint, the duration of the project often has to be increased

Resource Leveling of a Resource-Constrained Project

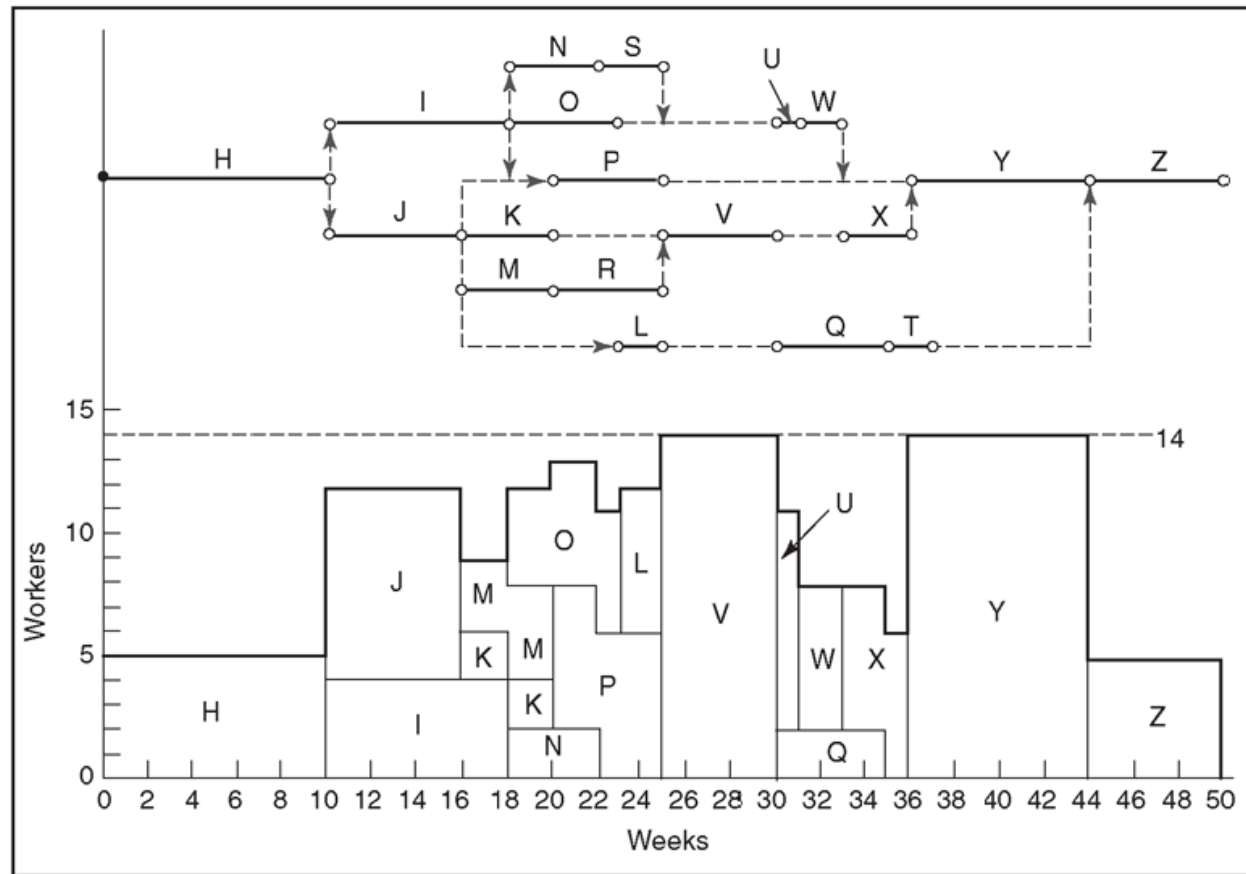

Figure 6-28
Schedule and corresponding worker loading for the LOGON project with 14-worker constraint.

Work Load

You need a company-wide system to manage workload on *all* projects concurrently

Why should smaller projects be loaded onto the system as well?

Small projects also contribute to the workload!
